



Beacon Tester

General description

406MHz BEACON TESTER is designed to check the maritime emergency radio beacons operating via COSPAS-SARSAT system such as Emergency Position Indicating Radio Beacon (EPIRBs).

The 406MHz BEACON TESTER is specified service equipment and reliable test solution for ship surveyors, beacon suppliers, classification societies and administrative authorities.

The 406MHz BEACON TESTER provides accurate independent validation of the operation of COSPAS-SARSAT distress beacons in a volume of:

- manual test requirements;
- shore-based maintenance under IMO resolutions requirements;
- fast check after beacon's encoding or installation.

406MHz BEACON TESTER can receive the transmission from any 406 MHz COSPAS-SARSAT beacons of any manufacturer transmitting both in test mode or in real alert emergency mode. Also the tester provides the reception and check of 121,5MHz home transmitter signal.

The signal can be received through the broadcast by means of antenna or the tester can be connected directly by means of cable through a suitable attenuator (option).

The tests can be performed in any room if the TEST MODE of distress beacon is used. Radiated tests in real alert emergency mode should be carried out using screened room (or enclosure) only.

Dimensions (mm)

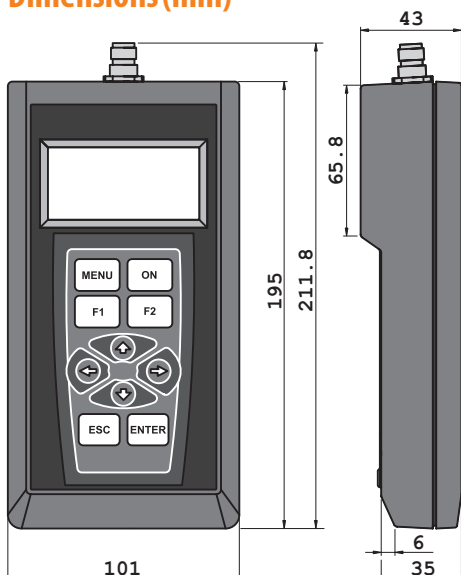

Operation / Features

It is very simple to check the distress beacon operation by means of 406MHz BEACON Tester.

Turn on the tester and then turn the beacon to TEST mode. Make sure that there is at least 3 meter (15 meter max) distance between the tester and the beacon and make some actions to carry out the test procedures.

The tester will receive the signal then measure the frequency meanings, power level in all channels, signal duration and then calculate and compare the BCH code. The tester will decode all emergency information automatically.

The tester provides demodulation and decoding of the emergency information and displays the HEX-code (15 Hex ID or the message 1-112 bit) on your choice as well as all decoded information in text view with all measured parameters. Besides the BCH code is calculated and compared with received one. All the result are displayed on the screen.



All data will be saved in memory for further processing. 10 memory blocks are available.

All emergency data can be viewed on the tester's LCD or can be transmitted to PC for further processing.

Since it is crucial for the beacon ID to be registered with the national authorities the 406 MHz BEACON Tester provides an easy means to verify the ID after installation or reprogramming.

The tester allows to perform the measurement of beacon parameters by means of standard external antenna (from 3 to 15 meters), as well as via high-frequency cable and attenuator connection.

Note: attenuator is required for power level measurements otherwise the power level will be only estimated.

The tester is lightweight, hand-held and has user-friendly operating interface, handy keyboard and LCD with backlight.

The tester power supply comes about by 4 AA batteries 1,5V as well as by external DC source with voltage 4,5...7V and load current no less than 300 mA.

This tester can be used for personal locator beacons testing (PLB) or for any other device operating within COSPAS-SARSAT system (SSAS, SVDR, VDR) testing.





Features:

- Reception the signal within the range of 406.020...406.040 MHz frequencies;
- Easy and quick audio-control of the sweep signal presence on 121,5 MHz frequency;
- Internal database of received messages with possibility to save upto 10 results;
- Easy connection to PC, laptop, notebook to process the stored data;
- Windows user friendly desktop application for database storage and review, process and test reports printout;
- Long life batteries, easy replace;
- Easy recalibration without returning back to factory;
- 1 year warranty.

PC Connection

On completing all the test it is required to process the measured data, make ready and print test reports using Tester PC software.

To do this the 406MHz tester can be easily connected to any PC or laptop. One can connect the device by means of standard USB A -USB A cable and special software available on this website. Also the special FTDI driver should be installed for proper connection. The minimal requirements are Microsoft OS (Windows XP, Windows Vista or Windows 7) and a USB port. No extra hardware configuration is required. All the downloads are available on the web-site.

Tester PC connection is very simple. All you have to do is to attach one side of the USB cable to the tester and the other one to the PC. Then install the drivers following the standard Windows wizard guidance. After the driver is installed run the software. No extra software installation is required. Just run the executive file and press DOWNLOAD MESSAGE button. All saved data will be transferred to PC.



The 406MHz BEACON Tester can be also described as:

- SARSAT Tester – as it is intended to check the COSPAS-SARSAT beacons;
- COSPAS-SARSAT or COSPAS Tester due to the same reason as it can check all types of C/S beacons;
- EPIRB Tester – as the tester is intended to check all types of maritime EPIRBs;
- PLB Tester - as the tester is capable to check any C/S PLB;
- 406MHz Tester – as the tester can measure the signals in this channel;
- SVDR Tester – as it can test S-VDR capsules;
- SSAS Tester – as the tester provide the possibility to check the Ship Security Alert Systems.

All these facilities are represented as single product - 406MHz BEACON Tester.

Technical description

The tester allows to perform:

- reception, demodulation and decoding of the emergency information transmitted on channel 406 Mhz;
- frequency measurement of 406 MHz signal in range of 406.020...406.040MHz with accuracy to ± 500 Hz.;
- audio-control of the sweep 121,5 MHz signal presence in range of 121500 ± 10 kHz.;
- power level measurement on 406 MHz channel within the range 19 – 43 dBm or 0,08W - 20W with accuracy to $\pm 3,0$ dB by means of antenna and 0,5 dB by means of attenuator;
- power level measurement on 121.5 MHz channel within the range 13 – 20 dBm or

- 20-100 mW with accuracy to $\pm 3,0$ dB by means of antenna and $\pm 0,5$ dB by means of attenuator;;
- estimation of the positive/negative phase deviation of modulated signal with accuracy to $\pm 2,8$ o;
- measurement of total transmission time of 406 MHz signal with accuracy to $\pm 0,2\%$;
- measurement of unmodulated carrier duration of 406 MHz signal;
- estimation of the equivalent radiated power of 406 MHz signal through broadcast.

The tester is designed to operate at the temperature range from 0oC to + 45oC and relative air humidity should be no more than 95%, which is determined by used LCD.

The tester power supply is performed by 4 AA batteries 1,5V, as well as by external DC source with voltage 4,5...7V and load current no less than 300 mA. The tester is power supplied by USB cable when connected to computer or net USB adapter.

Approximate continuous operation time of the tester from the internal power supply elements is about 6 hours.



Complete set of the 406MHz BEACON Tester

- 406MHz BEACON Tester
- Antenna
- PC cable (USB A – USB A 1.5m)
- 4 AA batteries
- Technical description and operation manual (English)
- Device packing
- High-frequency cable (optional)
- Attenuator (optional)
- Software and software user's manual (available at our website)



MUSSON MARINE
SAFETY SOLUTIONS

www.gmdsstesters.com
Buznika Str. 5, Nikolaev, Ukraine, 54010
Tel/Fax: +38 0512 584 199
E-mail: info@gmdsstesters.com